

# ENGWALD U-59-DT, DTH, UNITS

## UNDERFLOOR DISAPPEARING TWIN HOSES

EACH HOSE IN SEPARATE COMPARTMENT  
*Dimensions of units are on the following page*  
*ALL diagrams are not to scale*

### CONSTRUCTION

- Part 1 - Cast aluminum frame with beveled edges
- Part 2 - 3/4 or 7/8 Cast aluminum reinforced self closing lid
- Part 3 - 3/16 stainless steel pin
- Part 4 - Hose seal - filler plate
- Part 5 - 20 gage galvanized steel transition, coated with bituminous paint
- Part 6 - Cadmium plated spring
- Part 7 - Divider plate

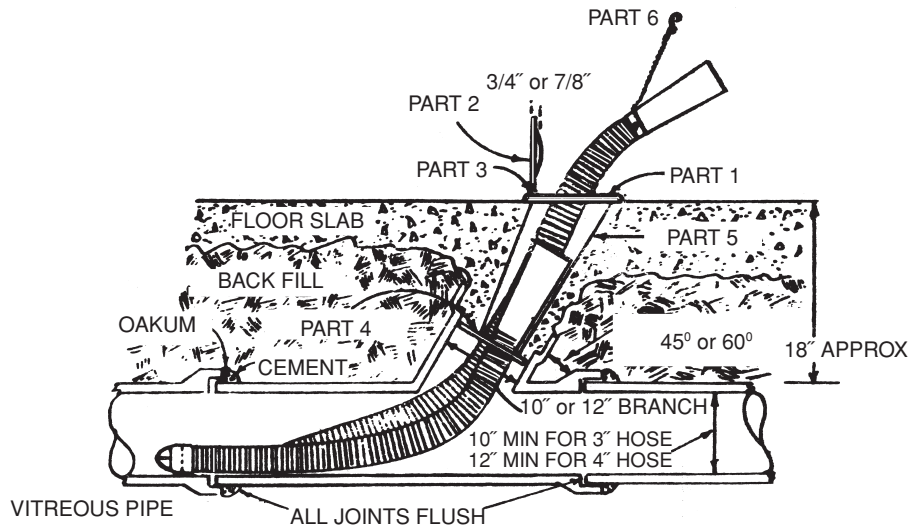

### TAILPIPE ADAPTER: ® GALVANIZED, ® STAINLESS STEEL

Number of outlets	Using galvanized hose	Using stainless steel hose
U-59-DT 3" SIZE	FT LONG	FT LONG
U-59-DTH 4" SIZE	FT LONG	FT LONG

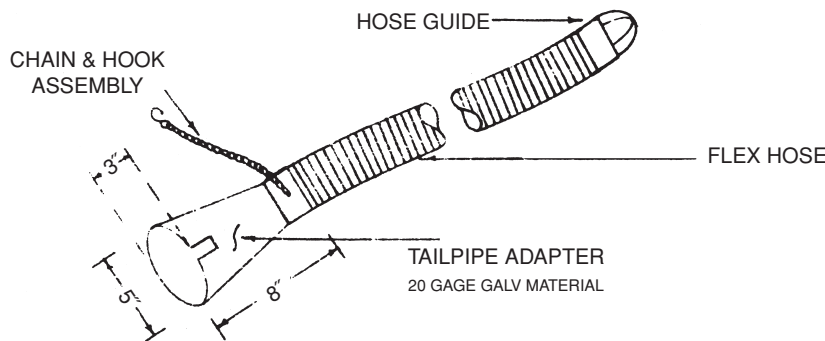

**3" HOSE**

**4" HOSE**

