

ENGWALD U-50-D, DH, DX, DXH UNITS

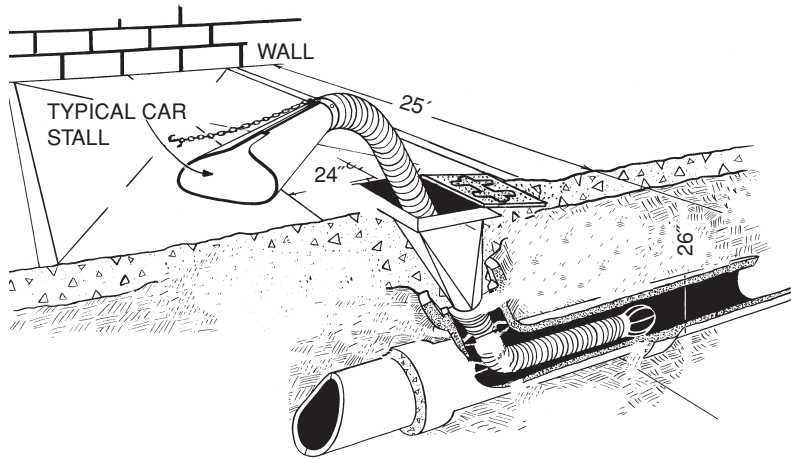

SINGLE UNDERFLOOR DISAPPEARING TYPE

Dimensions of units are on the following page
ALL diagrams are not to scale

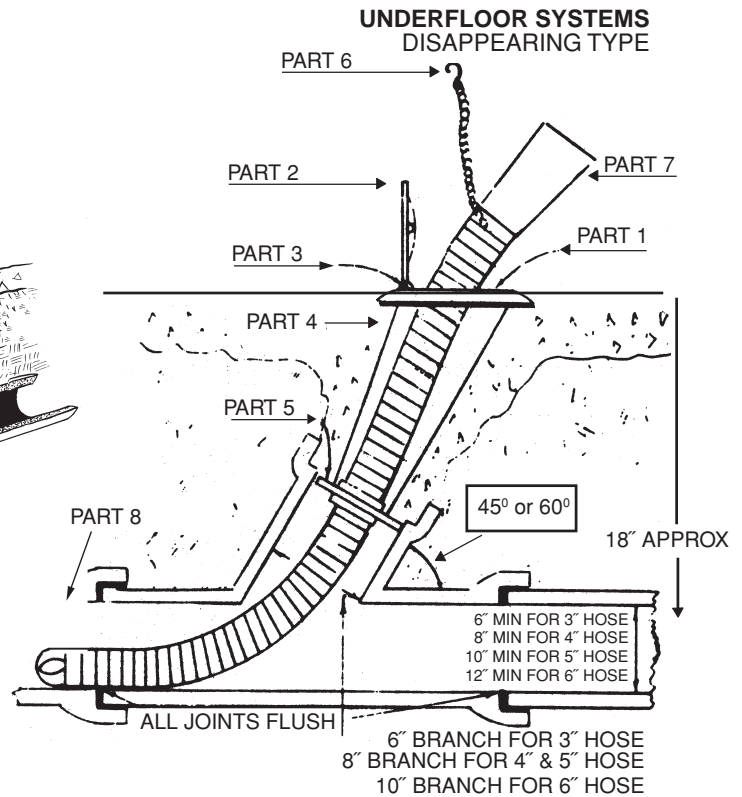

CONSTRUCTION

- Part 1 - Cast aluminum frame with beveled edges
- Part 2 - Cast aluminum reinforced lid
- Part 3 - 3/16 stainless steel pin
- Part 4 - 20 gage galvanized steel transition, coated with bituminous paint
- Part 5 - Hose seal - filler plate
- Part 6 - Chain and hook assembly
- Part 7 - Tailpipe adapter
- Part 8 - Hose guide

TAILPIPE ADAPTER: ® GALVANIZED, ® STAINLESS STEEL

Number of outlets	Using galvanized hose	Using stainless steel hose	Using crushproof neoprene hose
U-50-D 3" SIZE	FT LONG	FT LONG	FT LONG
U-50-DH 4" SIZE	FT LONG	FT LONG	FT LONG
U-50-DX 5" SIZE	FT LONG	FT LONG	NOT RECOMMENDED
U-50-DXH 6" SIZE	FT LONG	FT LONG	NOT RECOMMENDED

ENGWALD CORPORATION, Manufacturers of Exhaust Eliminating Systems, has after years of research and extensive testing by capable engineers, perfected various exhaust systems. These systems are the finest available and provide the ultimate in design and operating efficiency.

The ENGWALD U-50-D (3" HOSE SIZE) - Underfloor disappearing type outlet.

This model can be used with vitrified tile, transite pipe or sheet metal duct, the latter to be encased in concrete.

FLOOR RECEPTACLES are of heavy cast aluminum with hinged lids, transition of heavy gage galvanized steel dipped in rust-preventing bituminous paint, with a CAST ALUMINUM HOSE SEAL AND CENTERING CASTING at the base end of transition. This design allows a minimum leakage around hose at throat assembly. Constructed to last the life of your building.

HOSE ASSEMBLY consists of a length of flexible steel, or neoprene hose, steel-cage type hose guide and tailpipe adapter with chain and hook assembly. The tailpipe adapter is designed with a slot to be used with a gas analyzer.

The ENGWALD U-50-DH (4" HOSE SIZE)

It is designed the same as the above U-50-D (3") units. The 4" hose size is engineered to be used on trucks, buses and tractors, or any system that need a greater air volume. The unit comes with a 4" diameter hose which disappears into underfloor duct when not in use.

The ENGWALD U-50-DX (5" HOSE SIZE)

Same design as the above U-50-D (3") unit but larger opening and heavier reinforced lid. The 5" hose size is designed to be used on heavy trucks, heavy tractors and heavy diesels. Air movement per outlet 400 c.f.m.

Note: Duct and blower specifications and layouts will be furnished upon request by our engineers.

