

ENGWALD SADDLE UNITS U-50-DS, DHS, DXS, DXHS UNITS

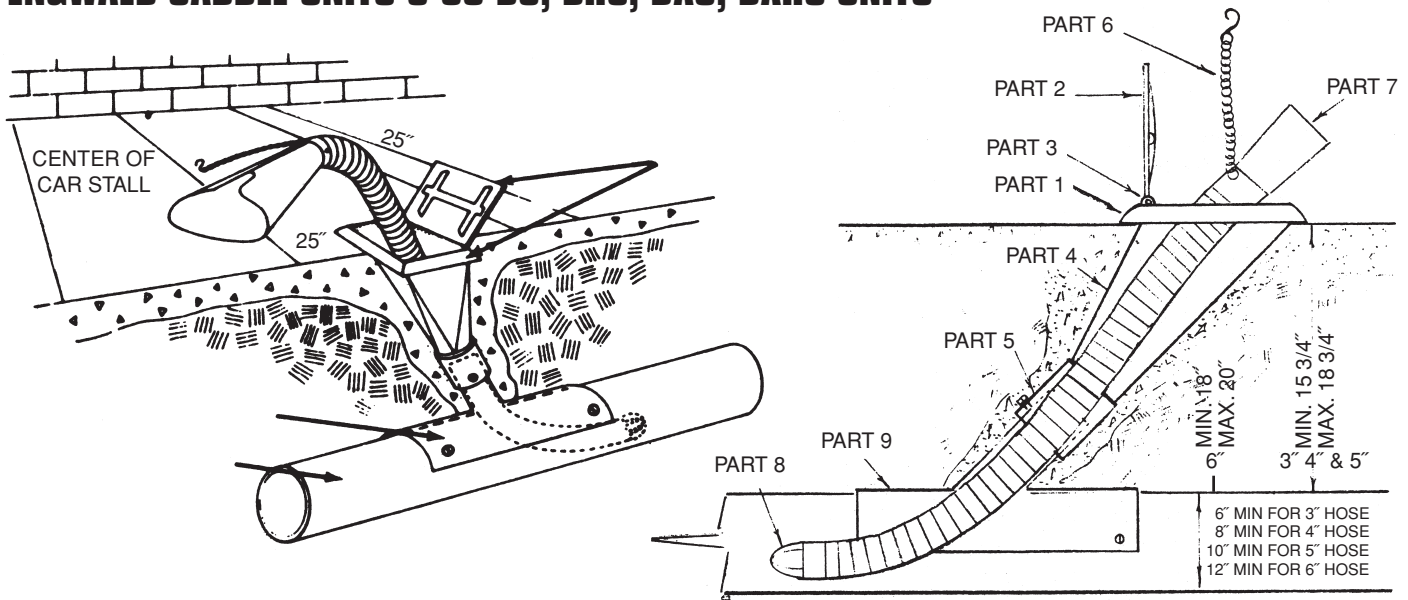

SINGLE UNDERFLOOR DISAPPEARING TYPE

Dimensions of units are on the following page
ALL diagrams are not to scale

CONSTRUCTION

- Part 1 - Cast aluminum frame with beveled edges
- Part 2 - Cast aluminum reinforced lid
- Part 3 - 3/16 stainless steel pin
- Part 4 - 20 gage galvanized steel transition, coated with bituminous paint
- Part 5 - Hose seal with adjustment screws
- Part 6 - Chain and hook assembly
- Part 7 - Tailpipe adapter
- Part 8 - Hose guide
- Part 9 - 18 gage saddle

TAILPIPE ADAPTER: ® GALVANIZED, ® STAINLESS STEEL

Number of outlets	Using galvanized hose	Using stainless steel hose	Using crushproof neoprene hose
U-50-DS 3" SIZE	FT LONG	FT LONG	FT LONG
U-50-DHS 4" SIZE	FT LONG	FT LONG	FT LONG
U-50-DXS 5" SIZE	FT LONG	FT LONG	NOT RECOMMENDED
U-50-DXHS 6" SIZE	FT LONG	FT LONG	NOT RECOMMENDED

ENGWALD CORPORATION, Manufacturers of Exhaust Eliminating Systems, has after years of research and extensive testing by capable engineers, perfected various exhaust systems. These systems are the finest available and provide the ultimate in design and operating efficiency.

The ENGWALD U-50-DS, U-50-DHS, U-50-DXS, AND DXHS SERIES - Underfloor disappearing type outlet. With this model the purchase of the "Y" fitting is eliminated. The unit sits directly on the straight pipe. The contractor is required to cut a whole into the pipe and then fasten unit to pipe with either self taping screws or with strapping. This unit is generally used with transite pipe or polyvinyl coated duct.

FLOOR RECEPTACLES are of heavy cast aluminum with hinged lids, transition of heavy gage galvanized steel dipped in rust-preventing bituminous paint, with a CAST ALUMINUM HOSE SEAL AND CENTERING CASTING at the base end of transition. This design allows an adjustment of approximately plus or minus 3".

HOSE ASSEMBLY consists of a length of flexible steel, or neoprene hose, steel-cage type hose guide and tailpipe adapter with chain and hook assembly. The tailpipe adapter is designed with a slot to be used with a gas analyzer.

THE ENGWALD 3", 4", AND 5" HOSE (depending upon system) disappear into underfloor duct when not in use.

Note: 5" size crushproof hose NOT available with U-50-DXS unit.

